

KM-15 HI-FI AMPLIFIER

FEATURES

- EXCELLENT PERFORMANCE AT LOW COST
- EQUALIZED PREAMP STAGE
- 12 WATTS OUTPUT — LOW DISTORTION
- WIDE FREQUENCY RESPONSE
- SEPARATE BASS AND TREBLE CONTROLS
- TUNER-PHONO SELECTOR SWITCH

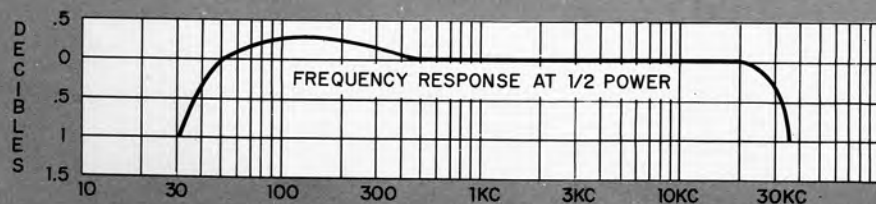

SPECIFICATIONS

- INPUTS** TUNER input; PHONO input
- RATED POWER** 12 Watts Continuous Sinewave; 14 Watts IHFM
- PEAK POWER** 24 Watts; 48 Watts IHFM
- FREQUENCY RESPONSE** $\pm 1\frac{1}{2}$ db, 30 to 15,000 cycles at 6 watts
- HARMONIC DISTORTION** Less than 1% at 12 watt, at 1 kc (through the TUNER input; Tone control settings normal)
- HUM AND NOISE** Better than 65db below 12 watts, referred to 1 volt input at TUNER
Better than 45 db below 12 watts, referred to 10 mv input at PHONO
- POWER SENSITIVITY** 5 mv at PHONO input for 12 watts output
1 volt at TUNER input for 12 watts output
- FEEDBACK** 15 db negative feedback
- CONTROLS** BASS control: 9 db of bass boost or cut at 40 cps
TREBLE control: 9 db of treble boost or cut at 10 kc
TUNER-PHONO selector switch
VOLUME control
- OUTPUT IMPEDANCES** 4, 8, and 16 Ω
- TUBE COMPLEMENT** 2—EL84/6BQ5, 2—ECC83/12AX7; EZ80/6V4 rectifier (may use alternate rectifiers EZ81/6CA4 or 6BW4)
- POWER CONSUMPTION** 50 watts at 117 volts, 60 cycle AC
- DIMENSIONS** 5" High, 9 $\frac{1}{2}$ " Wide, 6" Deep

CHECKING YOUR KIT

Before starting to build this kit, check each part against the parts list on page 20. This will help you become acquainted with each part. If you are unable to identify some parts by sight, locate their pictures on the wiring diagrams.

Symbols are used to describe parts. The Greek letter " μ " means micro, " Ω " means ohms, "K" means one-thousand, and "M" (or meg) means one million. Ten-percent tolerance resistors are used throughout, as shown by the fourth color band (silver) on each resistor.

Note the different types of screws supplied. Six of the screws are the self-tapping type and resemble wood screws. Of the others, the thicker screws are #6-32, and the thinner screws are #4-40.

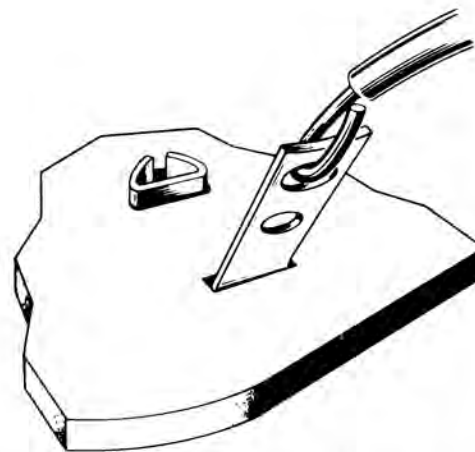

FIGURE 1. HOW TO CONNECT A WIRE TO A TERMINAL

CONSTRUCTION AND WIRING HINTS

READ THIS BEFORE YOU START TO BUILD

The only tools necessary for building your amplifier are: A pair of long-nose pliers, a pair of diagonal cutters, a screwdriver, and a soldering iron.

Study the pictorial diagrams and note how the parts are mounted. These pictorial diagrams show the actual location of all parts and wires. The schematic diagram (Figure 14) shows how the parts are connected electrically, and is helpful in understanding how the circuits work.

Be sure to follow the step-by-step instructions exactly. DO NOT wire this kit from the pictorials or schematic diagram alone, since it must be assembled and wired in a definite sequence. Occasionally, several parts are mounted with the same hardware, so be sure that you read each step all the way through. For your convenience, space is provided to check off each step after you have completed it.

Make good mechanical connections at solder points, clean metal to clean metal. Loop wires around socket and connection terminals, and clamp tightly to assure good mechanical connections. See Figure 1.

Unless otherwise stated, all the leads on the resistors, capacitors and transformers should be as short as possible. Figure 2 illustrates the best way to connect a component. As shown the end leads should be pulled through the terminals so that the part is tightly mounted. After a lead is pulled through a terminal, bend it around the terminal and cut off the excess wire.

The insulated wire furnished with this kit is cut to length, and the ends are stripped. The color of each wire stands for a definite length, so be sure to use the color specified in each of the wiring steps. A piece of heavy bare wire (busbar) is included. Whenever it is necessary to use some of it, the exact length is specified. DO NOT confuse it with the solder which is much softer and melts readily.

Flexible tubing, called "spaghetti", is supplied in two sizes — large diameter to fit over busbar and small diameter for other parts. Spaghetti is used to cover the bare end leads of some of the parts where there is a chance they will touch other bare wires or the chassis.

THIS KIT MUST BE PROPERLY SOLDERED!

USE ENOUGH HEAT

This is the main idea of good soldering. Apply enough heat to the metal surfaces you are joining to make the solder spread freely, until the contour (shape) of the connection shows under the solder.

AN ELECTRONIC UNIT WILL NOT WORK . . . unless it is properly soldered. Read these instructions carefully to understand the basic ideas of good soldering.

Enough heat must be used so the solder can actually penetrate the metal surfaces, making an unbroken path over which electricity can travel. You are not using enough heat if the solder barely melts and forms a rounded ball of rough, flaky solder.

Use the Right Soldering Tool

A soldering iron in the 40-100 watt range is recommended. Any iron in this range with a clean, chisel-shaped tip will supply the correct amount of heat to make a good solder connection. You may also use a solder gun but make sure the tip reaches full heat before you solder.

Keep the iron or gun tip brightly coated with solder. When necessary, wipe the hot tip clean with a cloth. If you are using an old tip, clean it before you start soldering. Use a fine file or steel wool to expose the bright metal. Heat the iron and immediately coat the tip with solder.

Use Only Rosin Core Solder

We supply the right kind of solder (*rosin core solder*). Do not use any other kind of solder! **Use of Acid Core Solder, Paste, or Irons Cleaned on a Sal Ammoniac Block will ruin any Electronic Unit and will Void the Guarantee.**

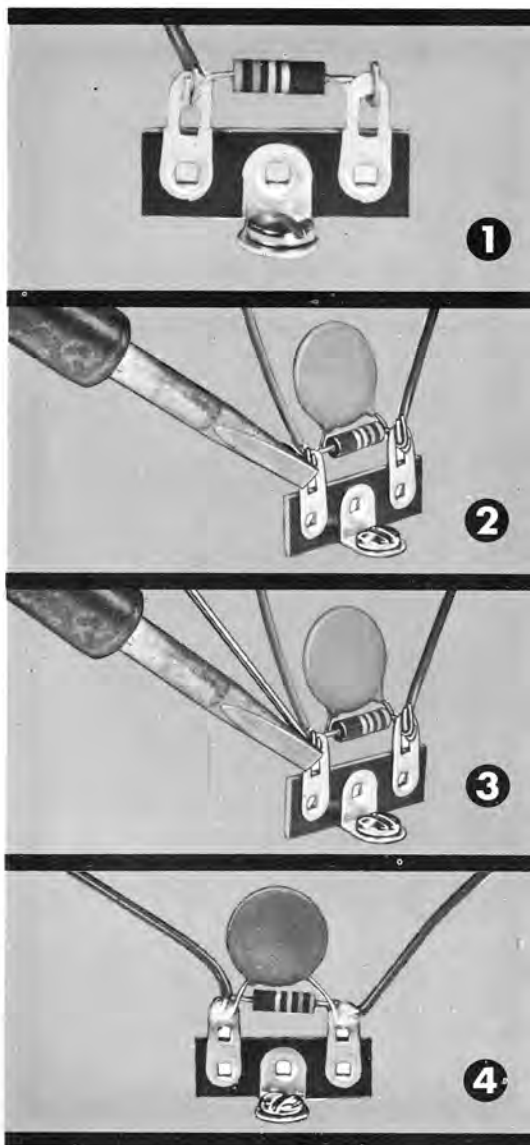

HERE'S HOW TO DO IT . . .

1. Join bare metal to bare metal; insulation must be removed. Make good mechanical connections and keep resistor and capacitor leads as short as possible, unless otherwise specified.

2. Coat the tip of a hot iron with solder. Then **Firmly Press the Flat Side of the Tip** against the parts to be soldered together. Keep the iron there while you . . .

3. Apply the solder between the metal to be soldered and the iron tip. Use only enough solder to flow over all surfaces of the connection, and all wires in the connection. Remove the iron.

Do Not Move Parts Until the Solder Hardens. If you accidentally move the wires as the solder is hardening, apply your iron and reheat.

4. Compare your soldering with the pictures on this page. You have a good connection if your solder has flowed over all surfaces to be connected, following the shape of the surfaces. It should appear smooth and bright and all wires in the connection should be well-soldered.

You Have Not Used Enough Heat: If your connection is rough and flaky-looking, or if the solder has formed a round ball instead of spreading.

The difference between good soldering (enough heat) and poor soldering (not enough heat) is just a few extra seconds with a hot iron **firmly** applied. **REMEMBER, LARGER METAL SURFACES TAKE A LONGER TIME TO HEAT.**

HOW TO CARE FOR YOUR SOLDERING IRON

Your soldering iron is the key to good soldering since it supplies the essential ingredient—HEAT. If the tip is covered by a dirt (oxide) film, the iron will not be able to transfer its full heat. A new tip can be protected from film by coating it with solder the first time it is heated. An old tip should first be cleaned with a file until bare copper is exposed. Then solder-coat it like a new tip.

Never use the iron like a brush—soldering is not a paste-spreading operation. To get the most heat out of the iron, always press the iron firmly to the connection. Hold it so the greatest tip surface is directly in contact with the connection.

MOUNTING THE PARTS

SEE FIGURE 5.

FROM TOP OF THE CHASSIS:

- Position T-1, the power transformer, so the side with five wires is closest to the side of the chassis. Secure with four lockwashers and nuts.
- See Figure 3. Insert four 4-40 screws through the mounting holes of the two tube shield bases, and through the chassis holes for the V-1 and V-2 sockets. (It may be necessary to thread the screws through with a screwdriver.) From inside the chassis, mount the V-1 and V-2 sockets on these screws. Position the keyways (the extra space between two pins) as shown. Secure with four lockwashers and nuts.
- From inside the chassis: Use the sandpaper supplied with the kit to scrape the paint away from a $\frac{1}{4}$ " area around the J-1 and J-2 mounting holes, exposing the bare metal.

These parts are mounted from INSIDE the chassis unless otherwise stated.

- Mount J-1 and J-2. Use four 4-40 screws, lockwashers and nuts.
- Mount S-1, the 6-terminal switch. Use two 4-40 screws.
- Mount S-2, the 2-terminal switch, positioning the end with the two terminals closest to T-1. Use two 4-40 screws.

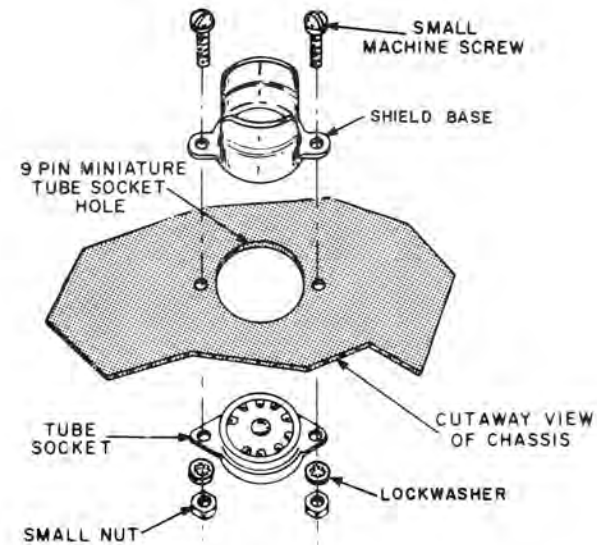

Figure 3. HOW TO MOUNT A TUBE SHIELD BASE

- Mount tube sockets V-3 and V-4. Be sure to position the keyways as shown. Use 4-40 screws, lockwashers and nuts.
- Use a 4-40 screw to mount TS-2, a 6-terminal strip, positioning the terminals as shown. On this screw, mount the V-5 socket, positioning the keyway as shown. Use another 4-40 screw and two lockwashers and nuts to mount the socket securely.
- Mount TS-3, a 6-terminal strip. Use a 6-32 screw, lockwasher and nut.
- Mount TS-4, a 2-terminal strip. Use a 6-32 screw, lockwasher and nut.
- Bend back slightly, ground terminals A, B, C, and D on V-1, V-2, V-3, V-4 and V-5. Use the tip of your screwdriver.

See Figure 4, How To Mount A Control. The three controls mount in the same manner, each using a flat washer inside the chassis, and a flat washer and nut on the bushing outside the chassis. If you do not have a lockwasher, use another flat washer in its place.

R-11 must not be used in place of R-13 or the circuit will not work as designed. They have different tapers although the value in ohms is the same. R-11 is marked with a color dot.

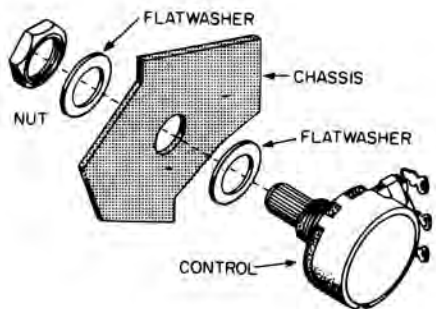

FIGURE 4. HOW TO MOUNT A CONTROL

- Mount R-11, the 50K Ω TREBLE control, marked with a color dot. Part no. 390100 is stamped on this control.
- Mount R-13, the 50K Ω BASS control, stamped with no. 390301.
- Mount R-8, the 500K Ω VOLUME control.
- Insert the three rubber grommets, as shown.

These parts mount from OUTSIDE the chassis.

- Mount TS-1, the four-screw terminal strip, from OUTSIDE THE REAR of the chassis. Position so terminal "C" is closest to the corner of the chassis. Use two 6-32 screws, lockwashers and nuts.
- From top of the chassis, install the mounting plate for C-16. Use two 6-32 screws, lockwashers and nuts.
- Notice that C-16, the 60-40-20-20 μ fd capacitor, has terminals identified by a square, a triangle, a bar, and a half-moon. Mount C-16 by inserting the mounting tabs in the mounting plate, positioning the terminals as shown. Secure by twisting the mounting tabs (ground terminals) $\frac{1}{8}$ turn with your pliers.

- Connect, but do not solder, the orange lead from T-1 to terminal 4 of TS-2.
- Twist the red leads together. Connect, but do not solder, one red lead to pin 7 of V-5. Connect, but do not solder, the other red lead to pin 1 of V-5.

REFER TO THE SOLDERING INSTRUCTIONS ON PAGE 4.

- Solder one of the black leads to terminal 1 of S-2. Connect, but do not solder, the other black lead to terminal 1 of TS-2.

NOTE: IN THIS MANUAL, WHEN THE WORD "SOLDER" APPEARS, IT MEANS CONNECT THE WIRE OR LEAD TO THE TERMINAL AND THEN SOLDER IT TOGETHER WITH ALL OTHER WIRES CONNECTED TO THE TERMINAL. EXTRA HEAT WILL BE NEEDED TO SOLDER A TERMINAL WITH SEVERAL LEADS.

- Twist the green leads together. Connect, but do not solder, one of them to terminal 2 of TS-2. Connect, but do not solder, the other green lead to terminal 6 of TS-2.
- Insert the green, yellow, black and white leads of T-2, the output transformer, through the grommet next to TS-1. Insert the red, blue and brown leads through the grommet closest to the V-3 and V-4 tube sockets. Mount T-2 with two 6-32 screws, lockwashers and nuts.

The T-2 leads connected to TS-1 must be straight, without loops.

- Connect, but do not solder, the yellow lead to terminal 16 of TS-1.
- Solder the green lead to terminal 8 of TS-1.
- Solder the white lead to terminal 4 of TS-1.
- Connect, but do not solder, the black lead to terminal C of TS-1.
- Connect, but do not solder, the red lead to terminal 1 of C-16.
- Solder the blue lead to pin 7 of V-4.
- Solder the brown lead to pin 7 of V-3.

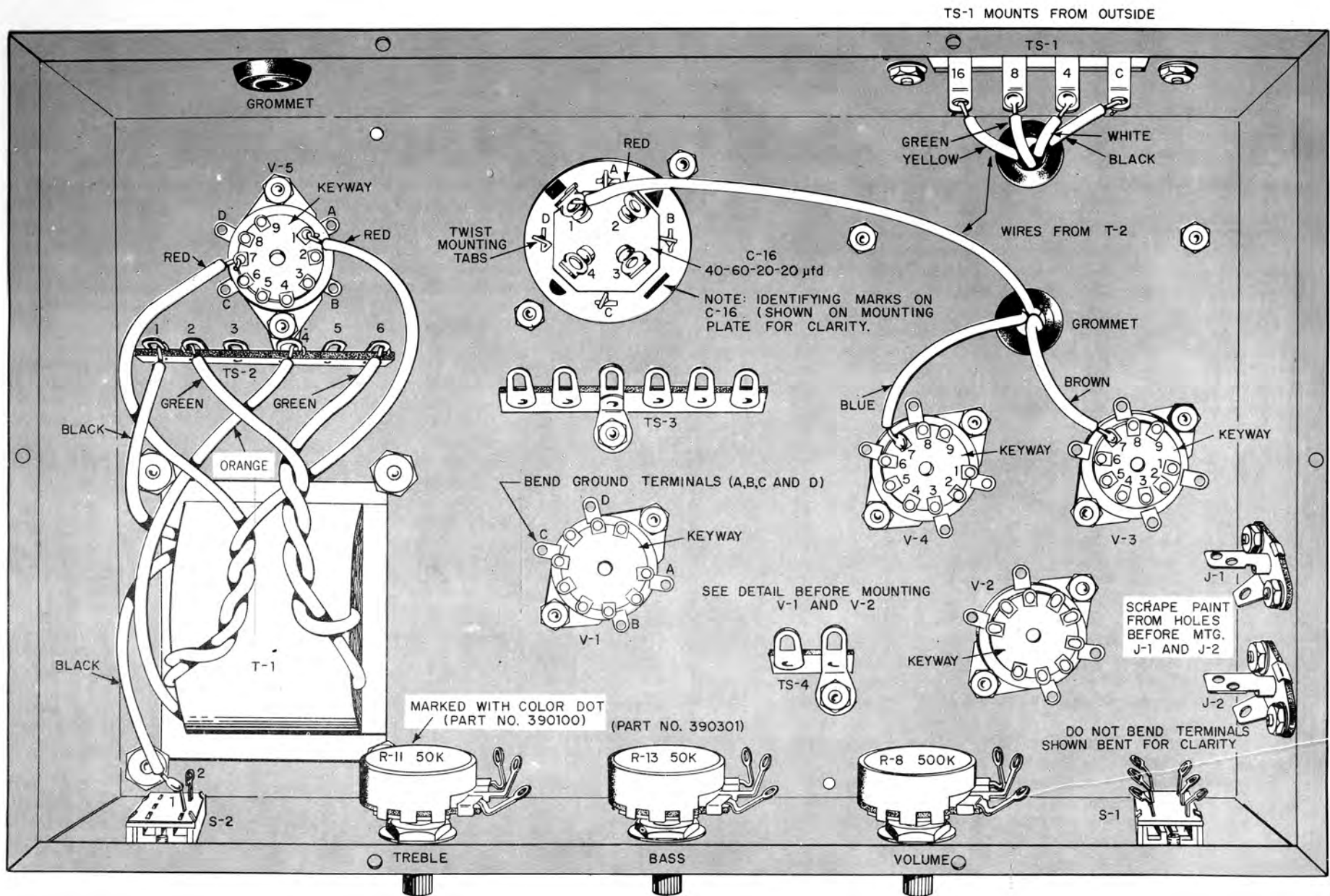

FIGURE 5. PARTS MOUNTING VIEW

FIRST WIRING

SEE FIGURE 6.

- Solder a 3½" busbar to ground terminal B of V-5. Bend as shown. Solder the other end to ground terminal A of C-16. More heat is needed to solder busbar. Apply your iron firmly for a few extra seconds.
- Solder ground terminal D of C-16 to the mounting plate.
- Form and route a 6½ busbar as shown, gently slipping it through terminal 1 of J-1 and J-2. Solder one end to terminal C of TS-1. Solder the other end to terminal 5 of S-1. **DO NOT BEND THE SWITCH TERMINALS!** Solder terminal 1 of J-2.
- Solder one end of a 2" busbar to ground terminal C of V-2. Route as shown. Hook the other end to terminal 1 of J-1, and solder it.
- Solder one end of a 1¼" busbar to ground terminal B of V-4. Solder the other end to ground terminal B of V-2.
- Solder one end of a 2¼" busbar to ground terminal A of V-1. Solder the other end to ground terminal C of V-4.
- Prepare one 9" and two 6" shielded cables as shown in Figure 7. Be careful not to cut the shield wire at one end of the cable. At the other end, cut the shield wire and the carbon shield back to the outer insulation. At each end, twist the strands of the inner conductor and coat lightly with solder.
- Connect, but do not solder, the shield wire of one of the 6" cables to terminal 2 of TS-4. Connect, but do not solder, the inner conductor at this end of the cable to terminal 1 of TS-4. Route as shown. Solder the other end of the inner conductor to terminal 16 of TS-1.
- Position the other 6" shield cable as shown, passing the end with the shield wire under the busbar between V-1 and V-4. Connect, but do not solder, the inner conductor at this end to terminal 6 of TS-3. Solder the shield wire to the busbar. Connect, but do not solder, the other end of the inner conductor to terminal 3 of S-1.
- Solder one end of a red wire to terminal 3 of S-1. Solder the other end to terminal 6 of S-1.
- Connect, but do not solder, the shield wire of the 9" cable to terminal 3 of TS-3. Connect, but do not solder, the inner conductor at this end to terminal 2 of TS-3. Connect, but do not solder, the other end of the inner conductor to terminal 2 of J-2.

- Connect, but do not solder, one end of a yellow wire to pin 9 of V-5. Connect, but do not solder, the other end to terminal 1 of C-16.
 - Twist two brown wires together tightly. At one end of the twisted pair, connect, but do not solder, either wire to terminal 3, and the other wire to terminal 5 of TS-2. At the other end of the twisted pair, connect, but do not solder, either wire to pin 5 and the other wire to pin 4 of V-3.
 - Twist two blue wires together tightly. At one end of the twisted pair, connect, but do not solder, either wire to terminal 3 and the other wire to terminal 5 of TS-2. At the other end of the twisted pair, solder either wire to pin 9 of V-1. Thread the other wire through pin 5, and solder to pin 4 of V-1. Solder pin 5 of V-1.
 - Slip ¾" of small spaghetti on one lead of R-6, a 150KΩ resistor (marked with color bands brown, green, yellow). Connect, but do not solder, this lead to pin 1 of V-1. Connect, but do not solder, the other lead to terminal 5 of TS-3.
 - Slip ¾" of small spaghetti on one lead of C-4, a .02 μfd (may be marked 20K or 20,000) disc capacitor. Connect, but do not solder this lead to pin 1 of V-1. Solder the other lead to terminal 6 of TS-3.
- Notice that the five tubular capacitors may have one end marked with a band. If so, position the banded end as shown.**
- Slip 2" of small spaghetti on the lead at the unbanded end of C-7, a .1 μfd tubular capacitor. Solder this lead to terminal 1 of R-11. Push C-7 down on the chassis. Thread the lead from the banded end through ground terminal B of V-1 and connect, but do not solder, it to pin 3 of V-1.
 - Use a ⅞" piece of bare wire previously clipped from the lead of a resistor or capacitor. Connect, but do not solder one end to pin 3 of V-1. Connect, but do not solder, the other end to pin 8 of V-1.
 - Slip 1¼" of small spaghetti on one lead of R-12, a 1KΩ resistor (brown, black, red). Connect, but do not solder, this lead to terminal 1 of R-13. Solder the other lead to ground terminal B of V-1.
 - Slip ½" of small spaghetti on one lead of C-10, a 200 μμfd (.0002) disc capacitor. Connect, but do not solder, this lead to terminal 3 of R-13. Solder the other lead to the busbar at ground terminal A of V-1.
 - Connect, but do not solder, one end of an orange wire to pin 9 of V-4. Connect, but do not solder, the other end to pin 9 of V-3.
 - Connect, but do not solder, one lead of R-20, a 1 megΩ resistor (brown, black, green), to pin 2 of V-3. Solder the other lead to the busbar near J-1, as shown.

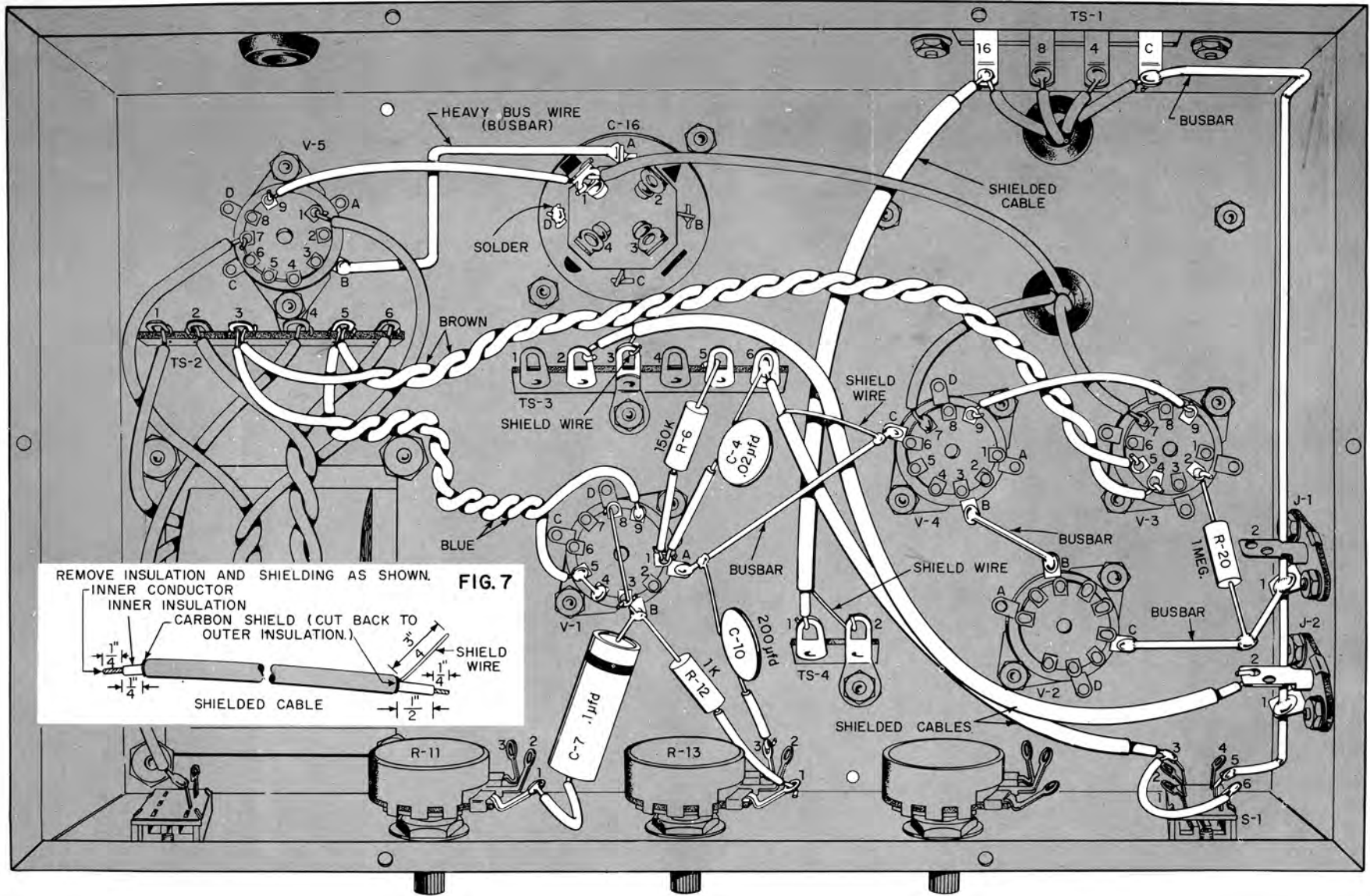

FIGURE 6. FIRST WIRING VIEW

SECOND WIRING

SEE FIGURE 8.

- Solder one end of a red wire to pin 8 of V-5. Connect, but do not solder the other end to pin 1 of V-5.
- Position C-13, a .022 μ fd tubular capacitor, as shown, with the unbanded end close to V-5. Solder the lead from the unbanded end to pin 1 of V-5. Connect, but do not solder, the lead from the banded end to the top hole of terminal 3 of TS-3.
- Slip 1-1/2" small spaghetti on the lead from the unbanded end of C-14, a .022 μ fd tubular capacitor. Solder this lead to pin 7 of V-5. Connect, but do not solder, the lead from the banded end to the top hole of terminal 3 of TS-3.
- Insert the bare ends of the line cord through the grommet on the rear of the chassis. Knot the cord about 6" from the ends. Split the two wires of the cord back to about 2" from the knot.
- Solder one of the line cord wires to terminal 2 of S-2. Trim the other wire to 2 1/2" from the knot. Remove 1/4" insulation from this end; twist the bare wires together and coat lightly with solder. Solder this wire to terminal 1 of TS-2.

CAUTION: DO NOT PLUG THE LINE CORD INTO A POWER OUTLET AT THIS TIME. THE WIRING IS NOT FINISHED.

- Solder one end of a red wire to pin 5 of V-5. Connect, but do not solder, the other end to terminal 2 of TS-2.
- Solder one end of a red wire to pin 4 of V-5. Connect, but do not solder, the other end to terminal 6 of TS-2.
- Connect, but do not solder, one lead of C-15, a .01 μ fd (10K or 10,000) disc capacitor, to terminal 4 of TS-2. Thread the other lead through terminal 3 and solder it to terminal 2 of TS-2. Solder terminal 3 of TS-2.
- Solder one lead of C-17, a .01 μ fd disc capacitor, to terminal 4 of TS-2. Thread the other lead through terminal 5 and solder it to terminal 6 of TS-2. Solder terminal 5 of TS-2.
- Connect, but do not solder, one lead of R-22, a 2.2K Ω , 1-watt resistor (red, red, red) to terminal 4 of C-16. Solder the other lead to terminal 1 of C-16.
- Connect, but do not solder, one end of a green wire to terminal 4 of C-16. Connect, but do not solder, the other end to pin 9 of V-4.
- Connect, but do not solder, one lead of R-24, a 120K Ω resistor (brown, red, yellow) to terminal 2 of C-16. Connect, but do not solder the other lead to ground terminal B of C-16.

NOTE: Be careful not to short (accidentally connect) two tube pins together when soldering the pins. Be sure to solder ALL leads connected to the pin.

- Connect, but do not solder, one lead of R-2, a 3.3 meg Ω resistor (orange, orange, green), to pin 7 of V-1. Solder the other lead to pin 8 of V-1.
- Connect, but do not solder, one lead of R-7, a 3.3 meg Ω resistor (orange, orange, green), to pin 2 of V-1. Solder the other lead to pin 3 of V-1.
- Slip 1/2" of small spaghetti on each lead of C-18, a .0068 μ fd (6.8K or 6800) disc capacitor. Connect, but do not solder, one lead to pin 2 of V-1. Connect, but do not solder, the other lead to terminal 2 of TS-4.
- Slip 7/8" of small spaghetti on each lead of C-6, a .015 μ fd (15K or 15,000) disc capacitor. Solder one lead to terminal 3 of R-11. Connect, but do not solder, the other lead to terminal 1 of TS-4.
- Slip 7/8" of small spaghetti on each lead of C-9, a .02 μ fd (20K or 20,000) disc capacitor. Connect, but do not solder, one lead to terminal 2 of R-11. Connect, but do not solder, the other lead to terminal 3 of R-13.
- Connect, but do not solder, one end of a yellow wire to terminal 2 of R-11. Connect, but do not solder, the other end to terminal 2 of R-13.
- Solder one end of a 1 1/4" busbar to terminal 2 of TS-4. Solder the other end to the busbar between V-1 and V-4.
- Slip 5/8" of large spaghetti on a 1" busbar. Solder one end to ground terminal C of V-3. Solder the other end to ground terminal A of V-4.
- Connect, but do not solder, one end of a red wire to pin 4 of V-3. Thread the other end through pin 5 of V-2 and solder it to pin 4 of V-2. Solder pin 5 of V-2.
- Connect, but do not solder, one end of a yellow wire to pin 5 of V-3. Route as shown. Solder the other end to pin 9 of V-2.
- Solder one end of an orange wire to pin 4 of V-4. Route as shown. Solder the other end to pin 4 of V-3.
- Solder one end of an orange wire to pin 5 of V-4. Route as shown. Solder the other end to pin 5 of V-3.
- Connect, but do not solder, one end of a red wire to terminal 4 of S-1. Solder the other end to terminal 1 of S-1.
- Slip 5/8" of small spaghetti on each lead of C-1, a .02 μ fd (20K or 20,000) disc capacitor. Solder one lead to terminal 4 of S-1. Solder the other lead to terminal 2 of J-1.

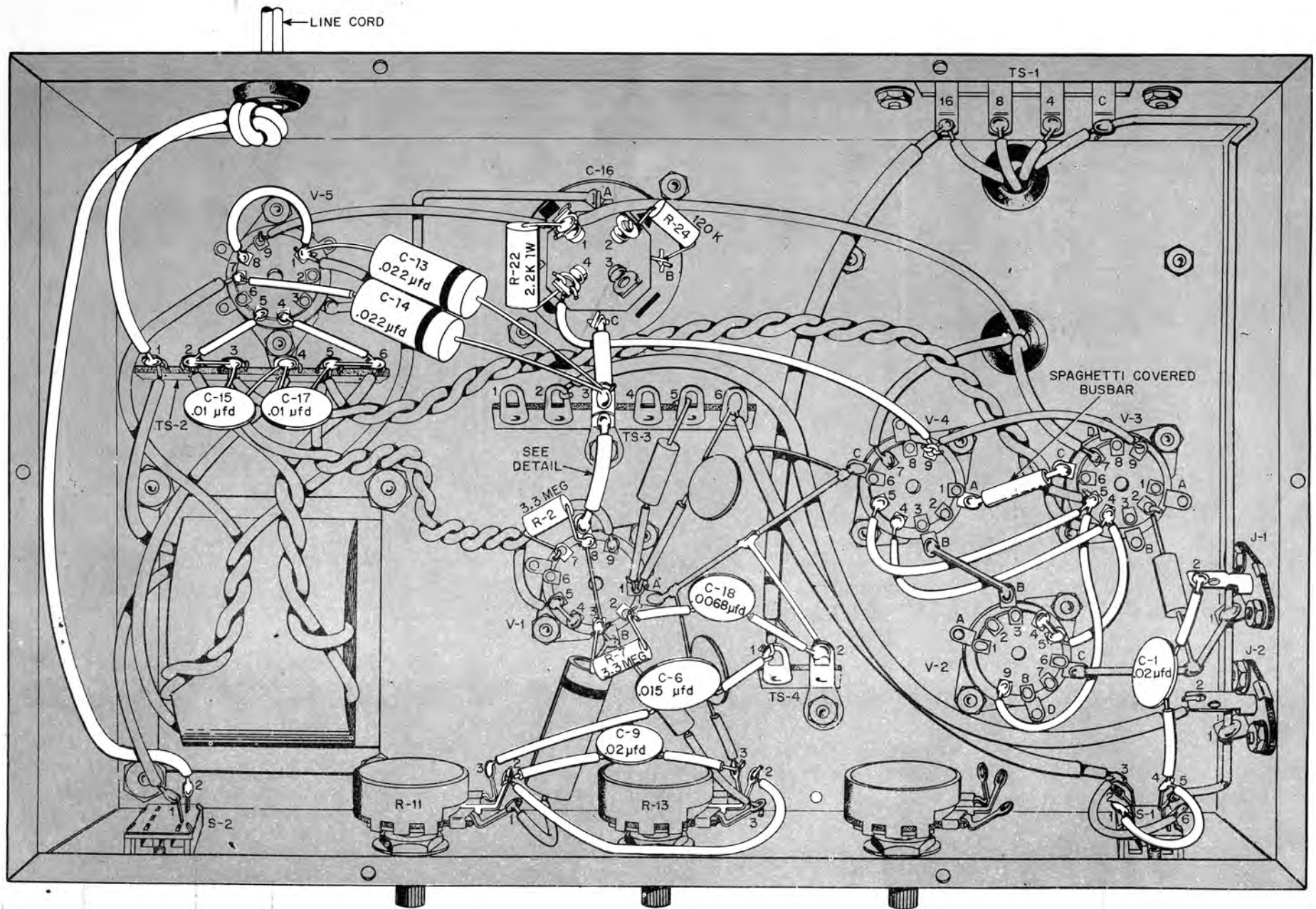

FIGURE 8. SECOND WIRING VIEW

See Figure 9. Pass $2\frac{1}{8}$ " busbar halfway through the bottom hole of terminal 3 of TS-3. Slip 1" of large spaghetti on the busbar between TS-3 and C-16 to protect the insulated wires under the busbar from the heat of soldering. Solder this end of the busbar to ground terminal C of C-16. Solder top and bottom holes of terminal 3 of TS-3.

Slip $\frac{1}{2}$ " of large spaghetti on the free end of the busbar. Solder this end to ground terminal D of V-1.

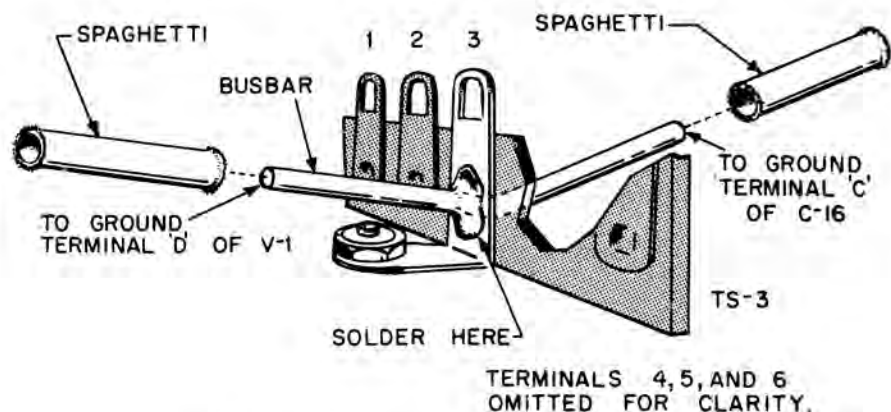

FIGURE 9. DETAIL ON WIRING OF BUSBAR

THIRD WIRING

SEE FIGURE 10.

Solder one end of a red wire to pin 9 of V-5. Solder the other end to pin 3 of V-5.

Note: Position the short red wires connected at V-5 so they do not touch any of the bare capacitor leads.

Connect, but do not solder, one end of an orange wire to terminal 2 of C-16. Connect, but do not solder, the other end to terminal 5 of TS-3.

Connect, but do not solder, one end of a green wire to terminal 3 of C-16. Connect, but do not solder, the other end to pin 3 of V-4.

Slip $\frac{3}{4}$ " small spaghetti on one lead of R-3, a 150K Ω resistor (brown, green, yellow). Solder this lead to terminal 5 of TS-3. Slip $\frac{1}{4}$ " of small spaghetti on the other lead. Connect, but do not solder, it to pin 6 of V-1.

Connect, but do not solder, one lead of C-5, a .02 μ f (20K or 20,000) disc capacitor, to pin 6 of V-1. Solder the other lead to pin 2 of V-1. Be sure that these leads do not touch other pins.

Solder one lead of R-14, a 10K Ω resistor (brown, black, orange), to terminal 3 of R-13. Solder the other lead to terminal 1 of TS-4.

Connect, but do not solder, one lead of R-21, a 1 meg Ω resistor (brown, black, green), to pin 2 of V-4. Solder the other lead to ground terminal A of V-2.

Connect, but do not solder, one lead of R-19, a 1.5 meg Ω resistor (brown, green, green) to pin 2 of V-2. Connect, but do not solder, the other lead to pin 2 of V-4.

Slip $\frac{1}{2}$ " of small spaghetti on each lead of C-12, a .02 μ f (20K or 20,000) disc capacitor. Solder one lead to pin 2 of V-4. Connect, but do not solder, the other lead to pin 1 of V-2.

Slip $\frac{1}{2}$ " of spaghetti on one lead of R-15, a 1K Ω resistor (brown, black, red). Thread this lead through pin 3; then solder it to pin 8 of V-2. Solder pin 3 of V-2. Solder the other lead to the busbar at ground terminal C of V-3.

Thread one lead of R-1, an 18K Ω resistor (brown, gray, orange), through ground terminal D of V-2. Solder this lead to terminal 3 of R-8. Solder ground terminal D of V-2. Solder the other lead to terminal 2 of J-2.

Slip $\frac{1}{2}$ " of small spaghetti on each lead of C-11, a .02 μ f (20K or 20,000) disc capacitor. Connect, but do not solder one lead to pin 6 of V-2. Connect, but do not solder, the other lead to pin 2 of V-3.

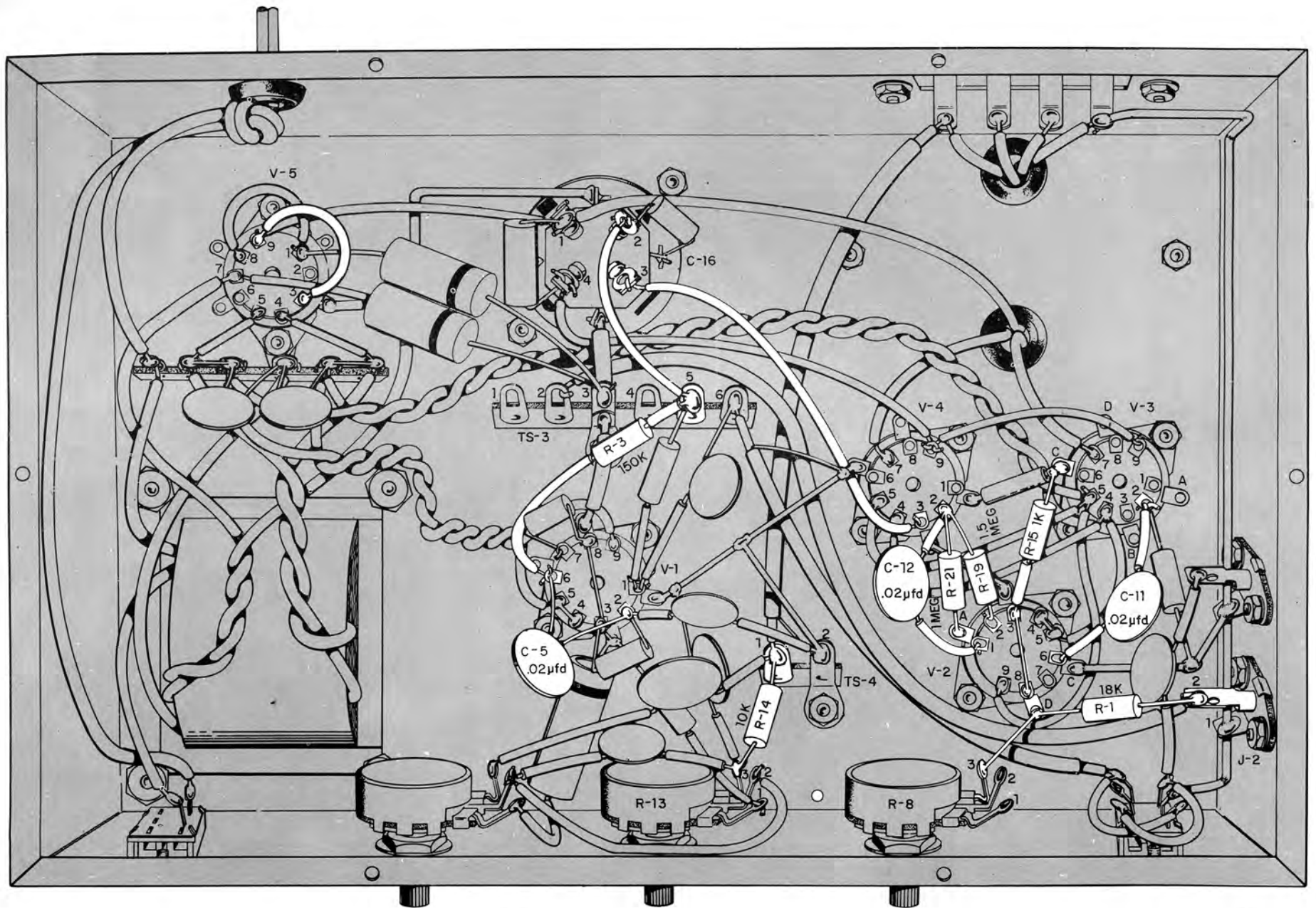

FIGURE 10. THIRD WIRING VIEW

FINAL WIRING

SEE FIGURE 11.

Solder one lead of R-23, an 82K Ω resistor (gray, red, orange), to terminal 2 of C-16. Solder the other lead to terminal 4 of C-16.

Solder one lead of R-25, a 220 Ω 2-watt resistor (red, red, brown) to ground terminal B of C-16. Solder the other lead to terminal 3 of C-16.

Slip $\frac{1}{2}$ " of small spaghetti on each lead of R-4, a 220K Ω resistor (red, red, yellow). Solder one lead to pin 6 of V-1. Connect, but do not solder, the other lead to terminal 4 of TS-3.

NOTE: Do not let solder flow between two tube pins. Solder between the pins would "short" them together.

Slip $\frac{1}{2}$ " of small spaghetti on one lead of R-5, a 1.5 meg Ω resistor (brown, green, green). Connect, but do not solder this lead to pin 1 of V-1. Connect, but do not solder, the other lead to terminal 4 of TS-3.

Slip $\frac{1}{2}$ " of small spaghetti on one lead of C-3, a .002 μ fd (2K or 2000) disc capacitor. Solder this lead to pin 1 of V-1. Solder the other lead to terminal 4 of TS-3.

Solder the lead from the banded end of C-2, a .1 μ fd tubular capacitor to terminal 2 of TS-3. Solder the other lead to pin 7 of V-1.

Note: Terminal 1 of TS-3 is not used.

Solder one end of an orange wire to pin 3 of V-4. Solder the other end to pin 3 of V-3.

Slip $\frac{3}{4}$ " of small spaghetti on each lead of R-17, a 220K Ω resistor (red, red, yellow). Solder one lead to pin 9 of V-4. Solder the other lead to pin 1 of V-2.

Slip $\frac{1}{2}$ " of small spaghetti on one lead of R-18, a 1.5 meg Ω resistor (brown, green, green). Solder this lead to pin 2 of V-3. Slip 1" of small spaghetti on the other lead of R-18. Solder the lead to pin 2 of V-2.

Slip 1" small spaghetti on each lead of R-16, a 220K Ω resistor (red, red, yellow). Solder one lead to pin 9 of V-3. Solder the other lead to pin 6 of V-2.

Connect, but do not solder, one lead of R-9, a 470K Ω resistor (yellow, violet, yellow), to pin 7 of V-2. Solder the other lead to terminal 2 of R-8.

Solder one end of a 1 $\frac{1}{2}$ " busbar to terminal 1 of R-8. Solder the other end to terminal 2 of S-1.

Slip 1 $\frac{1}{4}$ " of spaghetti on each lead of R-10, an 820K Ω resistor (gray, red, yellow). Solder one lead to pin 7 of V-2. Solder the other lead to terminal 2 of R-13.

Solder the lead from the banded end of C-8, a .25 μ fd tubular capacitor, to terminal 1 of R-13. Solder the other lead to terminal 2 of R-11.

The wiring of your amplifier is now completed, and all connections should be soldered. Carefully compare your wiring with the illustrations, to be sure there is no wiring error. Inspect all solder points for good connections. Touch a hot iron to any connections that look doubtful, to allow the solder to flow over all the wires in the terminal.

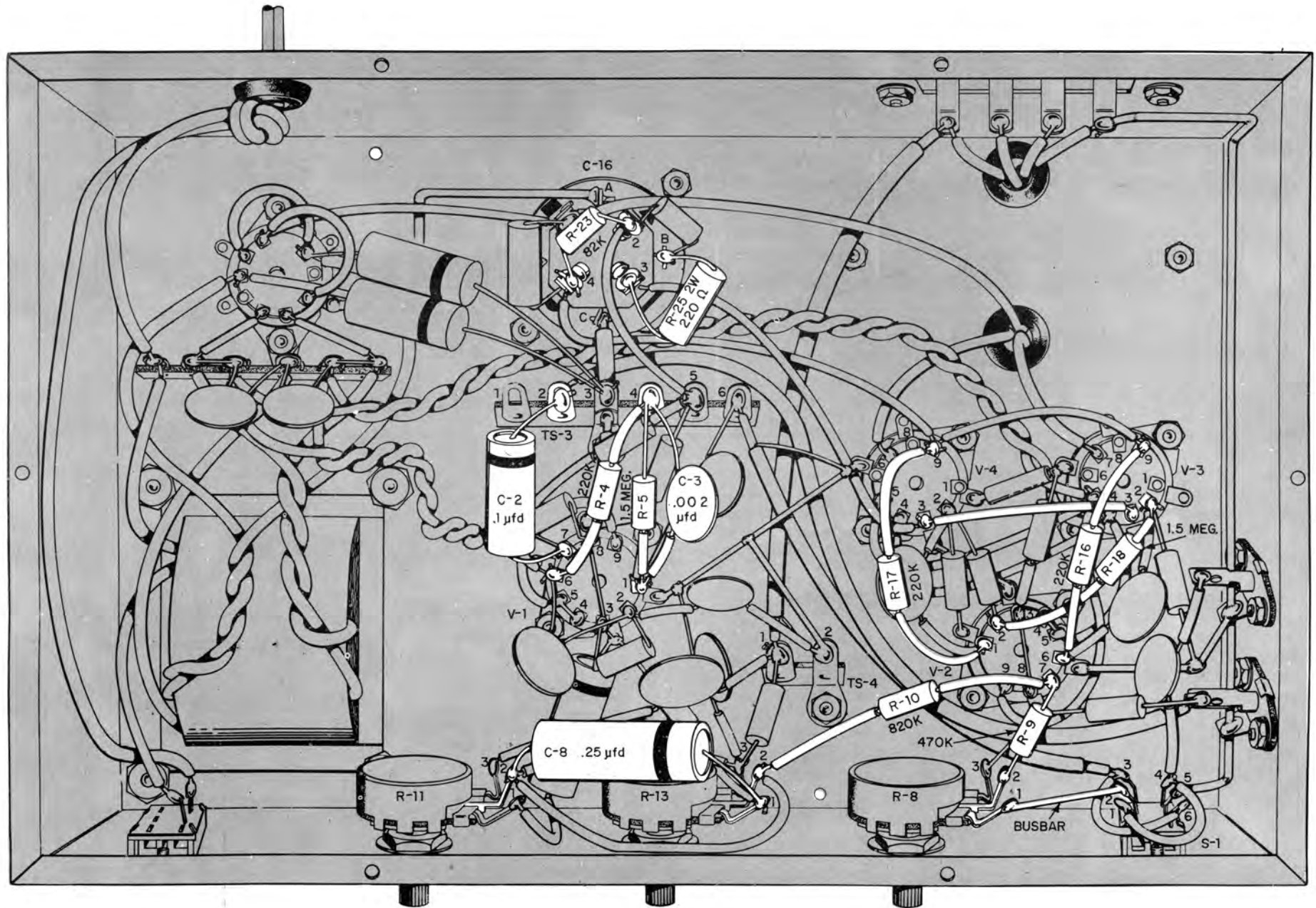

FIGURE 11. FINAL WIRING VIEW

FINAL ASSEMBLY

- Turn the shaft of R-8 to a midway position. Push the knob marked VOLUME on the shaft, so the mark on the knob lines up with the line on the front of the chassis when the control is at midway position. If the knob fits too loosely, use a screwdriver to spread the split shaft slightly.
- In a similar manner, push the BASS knob on the R-13 shaft, and the TREBLE knob on the R-11 shaft, so the mark on each knob lines up with the line on the chassis when these controls are in a midway position.
- See Figure 13. Insert the V-1, V-2, V-3, V-4 and V-5 tubes in their sockets, as shown.
- Place the tube shields over V-1 and V-2. Push the shields down until they are firmly seated.
- If you have purchased the ACCESSORY COVER, place it over the top of the chassis so the two mounting tabs line up with the two holes on top of the chassis. Secure from underneath the chassis with the two self-tapping screws supplied.
- Attach the bottom plate to the chassis, so the embossed feet are exposed. Fasten with six #4 self-tapping screws. If you are not using a top cover, be sure to protect the tubes during this step.

CONNECTING ASSOCIATED HI-FI EQUIPMENT

To get the most out of this fine amplifier, we suggest that you use it with a hi-fi speaker and enclosure. The tuner, record player, tape recorder, or microphone used with the amplifier should also be of good quality.

The amplifier has two inputs; PHONO for a magnetic phono cartridge; and TUNER for tuner, crystal or ceramic phono cartridge, or tape recorder.

SPEAKER

- Connect your speaker to the proper terminals on TS-1. For example, one wire from an 8Ω speaker is connected to the C or "common" screw-terminal. The other speaker wire would go to terminal 8.

CAUTION: Never turn on the amplifier unless the speaker is connected.

RECORD PLAYER

If your record player has a magnetic cartridge, plug the phono cable into the PHONO input of the amplifier. If your player has a ceramic or crystal cartridge, plug the phono cable into the TUNER input.

TUNER

Plug the output cable from your radio tuner (may be AM, FM or FM-AM) into the TUNER input of the amplifier.

TAPE PLAYBACK

Many tape recorders have provision for connection to an external amplifier for improved playback performance. If your tape recorder has this feature, connect the output cable from the preamplifier section of the tape recorder to the TUNER input of your amplifier.

HOW TO CONNECT A PIN PLUG

If you wish to connect a pin plug to your record player or tuner cable, see Figure 12.

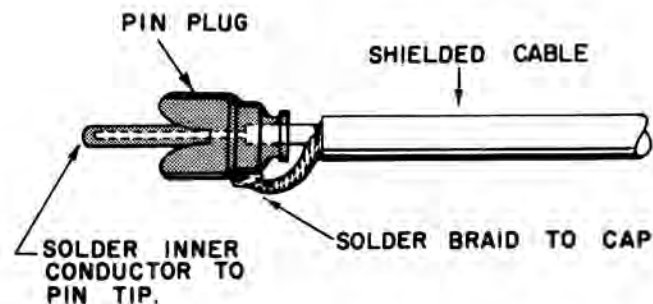

FIGURE 12. HOW TO CONNECT A PIN PLUG

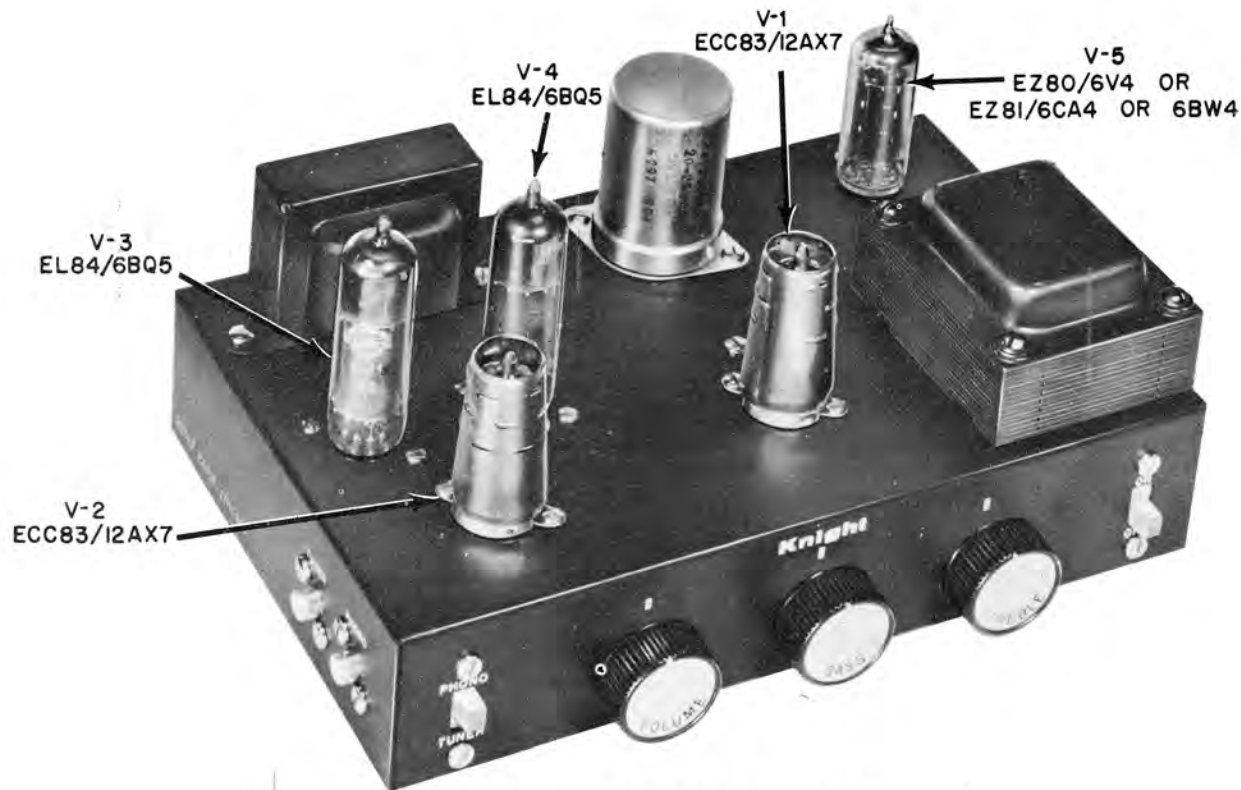

FIGURE 13. TOP VIEW OF AMPLIFIER

RESISTANCE CHART

All readings made with OFF-ON switch OFF and all controls turned fully counterclockwise. Resistances measured to chassis ground, except:

- * Measured to terminal 2 of C-16 (marked with a triangle)
- † Measured to terminal 4 of C-16 (marked with a half-moon)
- § Measured to terminal 1 of C-16 (marked with a square)

N.S.=Not Significant.

TUBE	PIN								
	1	2	3	4	5	6	7	8	9
V-1	150K*	3.3M	0	N.S.	N.S.	150K*	3.3M	0	N.S.
V-2	220K†	1.25M	1K	N.S.	N.S.	220K†	300K	1K	N.S.
V-3	N.S.	800K	220	N.S.	N.S.	N.S.	180§	N.S.	0†
V-4	N.S.	800K	220	N.S.	N.S.	N.S.	180§	N.S.	0†
V-5	200	N.S.	2.2K† 84K*	N.S.	N.S.	N.S.	200	200	2.2K† 84K*

OPERATING INSTRUCTIONS

- Turn the ON-OFF switch to OFF. Turn VOLUME all the way to the left. Plug the amplifier line cord into a power outlet supplying 110-120 volts, 60 cycle AC.

CAUTION: DO NOT ATTEMPT TO OPERATE FROM A DIRECT CURRENT (DC) SOURCE OF POWER. IF IN DOUBT AS TO THE TYPE OF POWER YOU HAVE, CHECK WITH YOUR LOCAL ELECTRIC COMPANY.

NEVER REMOVE THE BOTTOM PLATE WHEN THE AMPLIFIER LINE CORD IS PLUGGED IN. DO NOT OPERATE ON A SINK, RADIATOR, OR ANY OTHER GROUNDED METAL OBJECT.

LISTENING TO RADIO BROADCASTS (OR TAPE RECORDER)

- Plug in the line cords of your associated equipment to a suitable power source. Turn the ON-OFF switch of your tuner (or tape recorder) to ON. Set the tuner dial at the desired station. If unit has its own volume control, set it temporarily at half-way. Set the amplifier TUNER-PHONO switch to TUNER.

- Turn the amplifier ON-OFF switch ON, and allow a minute for warm-up. Turn VOLUME to the right, to the desired listening level.

LISTENING TO RECORDS

- Set the amplifier TUNER-PHONO switch to PHONO. Turn the amplifier ON-OFF switch ON, and allow a minute for warm-up. Play a record and turn the VOLUME control to the right, to the desired listening level.

BASS AND TREBLE CONTROLS

These controls allow flexible combination of bass and treble to match room acoustics. For different program material, you will probably prefer different settings of these controls. It's a lot of fun to experiment for the most pleasing effect. Turn control to the left for less BASS or TREBLE — turn to the right for more BASS or TREBLE. Flat or normal position is the setting where the mark on the knob points to the line on the chassis.

SERVICE HINTS

If your 12-Watt Hi-Fi Amplifier does not perform satisfactorily the first thing to do is to recheck all the wiring. (Be sure to remove the line cord plug from the power outlet before you remove the bottom plate to inspect the wiring.) One incorrect connection or a poorly soldered connection can cause the whole amplifier to be inoperative. If there are several wires in one connection, make sure all the wires are soldered.

Most cases of poor performance are caused by a wiring error, or the failure to use enough heat when soldering. A friend who is familiar with electronics can help you find a mistake in the wiring that you may have overlooked.

A "motorboating" sound may be heard if you accidentally put the TUNER-PHONO switch in the PHONO position and do not have a record player cable plugged into the PHONO input. In this case, just place the switch in the correct TUNER position.

HOW IT WORKS

The 12-Watt Amplifier can be driven to full rated output by introducing a signal from a tuner or crystal cartridge at J-1, or a signal from a magnetic cartridge at J-2. The S-1 switch selects either TUNER input or phono preamplifier, grounding out the one not in use to prevent crosstalk between the inputs. R-1 is the terminating resistor for magnetic cartridges.

The circuits of V-1, an ECC83/12AX7 tube, provide preamplification and equalization for magnetic cartridges. The two sections of this tube, V-1A and V-1B are connected as a cascade amplifier to obtain the high gain needed. Both cathodes are grounded for better shielding, reducing hum. Bias is derived by use of grid-leak resistors R-2 and R-7. Equalization is achieved by plate to plate feedback through C-3 and R-4, with R-5 limiting the bass boost to prevent rumble.

V-2, an ECC83/12AX7 tube, is connected as a modified self-balancing see-saw phase inverter. It splits the signal into two signals, 180 degrees out of phase with each other, as required to drive a push-pull output stage. Phase inversion takes place because the cathode of V-2A is tied to the cathode of V-2B, and the grid of V-2B is in effect grounded. V-2A operates as a conventional amplifier, with a positive-going signal at the grid appearing as a negative-going signal at the plate, and positive-going signal at the cathode. Since both cathodes are tied together, the cathode of V-2B will also go positive, and the grid of V-2B will go negative with respect to the cathode. This results in a positive-going output signal at the plate of V-2B at the same time the output of V-2A is going negative.

Precision results are achieved with ordinary tolerance components because of the self-compensating features of this circuit. Self-balancing features include use of a common cathode resistor, R-15, to provide a large amount of degeneration, and use of the midpoint between R-18 and R-19 as a reference level for balancing purposes. This point will be at zero potential if the two halves of V-2 are perfectly balanced. However, if one half has more gain than the other, a correction signal appears at this point, and applied to the grid of V-2B, corrects the unbalance.

One signal from V-2 is coupled through C-11 to the grid of V-3. The other signal from V-2, 180 degrees out of phase with the signal going to V-3, is coupled through C-12 to the grid of V-4. V-3 and V-4, EL84/6BQ5 output tubes are connected for push-pull operation, with their cathodes tied together, and their plates connected to opposite ends of the primary winding on the output transformer. In this way, the output of the two tubes is combined in the output transformer, resulting in the desired reduction of distortion by cancelling out harmonics and hum.

Feedback voltage is taken from the secondary of T-2 and serves a dual purpose — for tone control, and to reduce distortion. The feedback voltage is divided by filters so that high frequencies go to the TREBLE control, R-11, and low-frequencies go to the BASS control, R-13. Moving either control clockwise (upward on the schematic) reduces the amount of feedback of the selected frequencies, resulting in an increase of bass or treble, as the case may be.

T-2, the output transformer, has a 10K Ω primary to match the impedance of the output tubes. The secondary has taps to match 4, 8 or 16 Ω speakers. The output transformer delivers the amplified electrical signals to your speaker. The speaker changes the electrical signals to audible sound.

The power supply includes the T-1 power transformer, an indirectly heated rectifier tube, V-5, and a multiple-section filter capacitor, C-16. C-13, C14 and C-15 further improve the power supply by filtering out rectifier "hash".

EQUIPMENT USED FOR SPECIFICATION MEASUREMENTS

Hewlett-Packard Model 400D AC VTVM
Simpson Model 390 Wattmeter

Hewlett-Packard Model 200CD Audio Generator
Simpson Model 260 VOM

Barker-Williamson Model 400 Distortion Analyzer
Triplett Model 630 VOM

Tektronix Model 531 Oscilloscope

PARTS LIST

Symbol No.	Description	Part No.
CAPACITORS		
C-1	.02 μ fd ceramic disc.....	N276025
*C-2	.1 μ fd tubular.....	N293004
C-3	.002 μ fd ceramic disc.....	N276026
C-4	.02 μ fd ceramic disc.....	N276025
C-5	.02 μ fd ceramic disc.....	N276025
C-6	.015 μ fd ceramic disc.....	N276156
*C-7	.1 μ fd tubular.....	N293004
*C-8	.25 μ fd tubular.....	N293005
C-9	.02 μ fd ceramic disc.....	N276025
C-10	200 μ fd ceramic disc.....	N276027
C-11	.02 μ fd ceramic disc.....	N276025
C-12	.02 μ fd ceramic disc.....	N276025
*C-13	.022 μ fd tubular.....	N297008
*C-14	.022 μ fd tubular.....	N297008
C-15	.01 μ fd ceramic disc.....	N276015
C-16	60-40-20-20 μ fd, 375-350-150-25 v. electrolytic.....	N234400
C-17	.01 μ fd ceramic disc.....	N276015
C-18	.0068 μ fd ceramic disc.....	N276687

CONNECTORS		
J-1	Pin jack.....	N502220
J-2	Pin jack.....	N502220
	Pin plugs (2).....	N502123

RESISTORS		
All are 10% tolerance, 1/2 watt resistors, otherwise specified.		
R-1	18 K Ω	N301183
R-2	3.3 meg Ω	N301335
R-3	150K Ω	N301154
R-4	220K Ω	N301224
R-5	1.5 meg Ω	N301155
R-6	150K Ω	N301154
R-7	3.3 meg Ω	N301335
R-8	500K Ω VOLUME control.....	N390000
R-9	470K Ω	N301474
R-10	820K Ω	N301824
R-11	50K Ω TREBLE control with linear taper.....	N390100
R-12	1K Ω	N301102
R-13	50K Ω BASS control with reverse log. taper.....	N390301
R-14	10K Ω	N301103
R-15	1K Ω	N301102
R-16	220K Ω	N301224
R-17	220K Ω	N301224
R-18	1.5 meg Ω	N301155

Symbol No.	Description	Part No.
R-19	1.5 meg Ω	N301155
R-20	1 meg Ω	N301105
R-21	1 meg Ω	N301105
R-22	2.2K Ω , 1-watt.....	N304222
R-23	82K Ω	N301823
R-24	120K Ω	N301124
R-25	220 Ω , 2-watt.....	N307221

SWITCHES		
S-1	TUNER-PHONO selector switch (6 terminals).....	N431304
S-2	ON-OFF switch (2 terminals).....	N431006

TRANSFORMERS		
T-1	Power transformer.....	N101313
T-2	Output transformer.....	N102208

TUBES		
V-1	ECC83/12AX7.....	N611012
V-2	ECC83/12AX7.....	N611012
V-3	EL84/6BQ5.....	N610056
V-4	EL84/6BQ5.....	N610056
V-5	EZ80/6V4 or EZ81/6CA4 or 6BW4.....	N611028

TERMINAL STRIPS		
TS-1	4-screw strip stamped 16, 8, 4, C.....	N441401
TS-2	6-terminal strip.....	N440601
TS-3	6-terminal strip.....	N440601
TS-4	2-terminal strip.....	N440202

MISCELLANEOUS		
Description	Quan.	Part No.
Bottom plate.....	1	N463107
Capacitor mounting plate, metal.....	1	N501542
Chassis.....	1	N461208
Grommet, rubber.....	3	N830200
Knob for BASS control.....	1	N763001
Knob for TREBLE control.....	1	N763002
Knob for VOLUME control.....	1	N763000
Sandpaper square.....	1	N860014
Shield base.....	2	N511001
Tube shield.....	2	N510001
Tube socket, 9-pin.....	5	N501190

Description	Quan.	Part No.
WIRE, SOLDER AND SPAGHETTI		
Busbar (heavy barewire), 24".....	1	N806424
Insulated shielded wire, 9".....	3	N803035
Insulated solid wire		
2" red.....	7	N801002
3" orange.....	5	N801003
4" yellow.....	3	N801004
5" green.....	2	N801005
6" blue.....	2	N801006
10" brown.....	2	N801010
Line cord.....	1	N802001
Solder, 48".....	1	N930004
Spaghetti small-diameter.....	34"	N812001
Spaghetti, large-diameter.....	7"	N812003

HARDWARE		
Flatwasher, 25/64".....	6	580702
Lockwasher, #4.....	14	582200
Lockwasher, #6.....	12	582300
Lockwasher, #8.....	4	582400
Screws, #4 self-tapping.....	6	562292
Screws, 4-40.....	18	560222
Screws, 6-32.....	16	560342
Nuts, 4-40.....	14	570220
Nuts, 6-32.....	12	570340
Nuts, for Power transformer.....	4	570440
Nuts, 3/8"-32.....	3	570840

*Note: The tubular capacitors can be mounted in either direction, so please disregard banded end of the capacitors in Figure 6, Figure 8 and Figure 11.

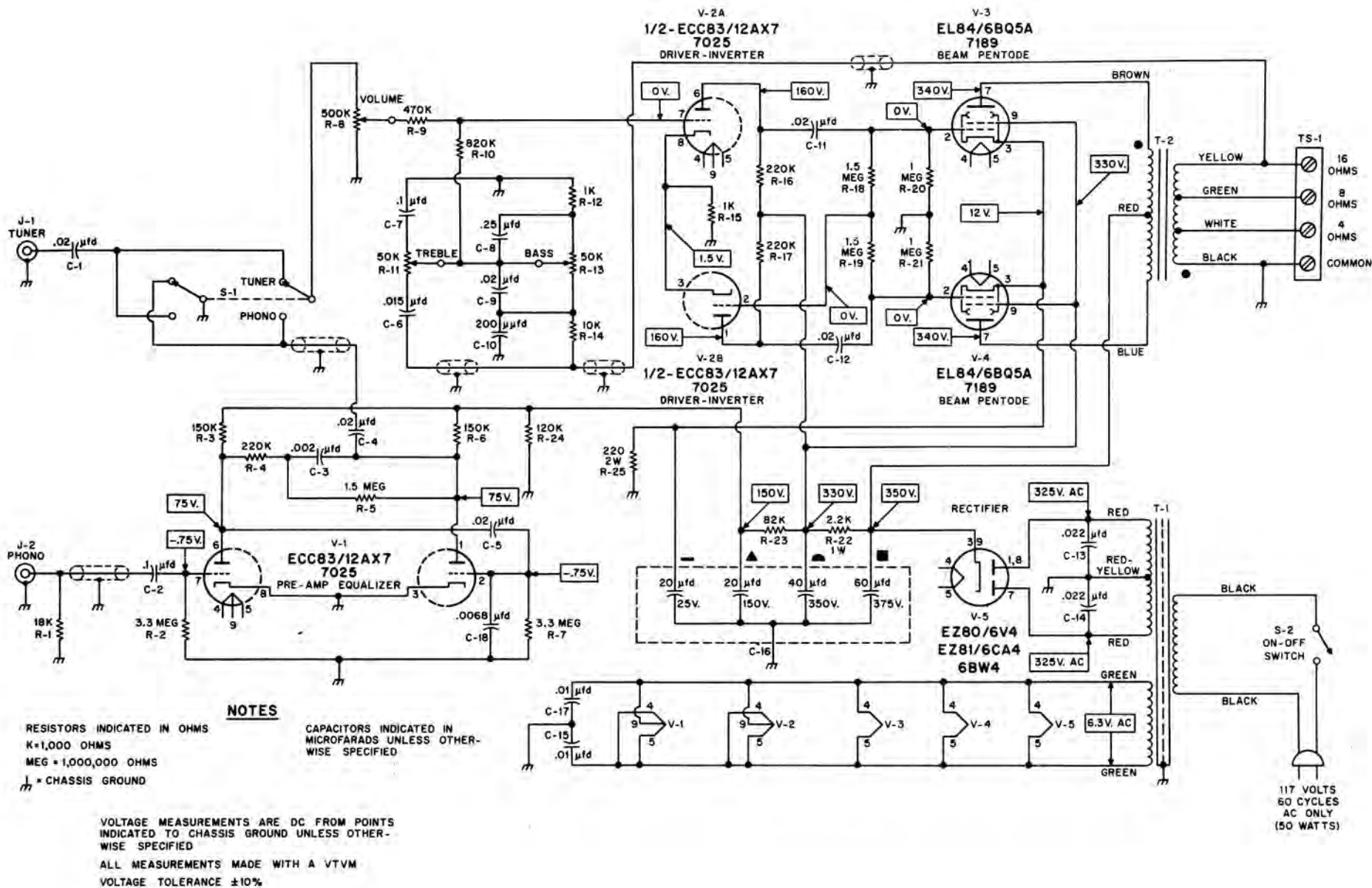
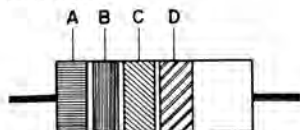

FIGURE 14. SCHEMATIC DIAGRAM

CAPACITOR AND RESISTOR COLOR CODE

RESISTOR-MICA CAPACITOR COLOR CODE				
Color	Significant Figures	Multiplier	Tolerance %	Voltage Rating*
Black	0	1	±20*	—
Brown	1	10	±1*	100
Red	2	100	±2*	200
Orange	3	1,000	±3*	300
Yellow	4	10,000	±4*	400
Green	5	100,000	±5*	500
Blue	6	1,000,000	±6*	600
Violet	7	10,000,000	±7*	700
Gray	8	100,000,000	±8*	800
White	9	—	±9*	900
Gold	—	.1	±5	1,000
Silver	—	.01	±10	2,000
None	—	—	±20	500

*Applies to capacitors only



HOW TO DETERMINE THE VALUE OF A RESISTOR

- A — First significant figure (digit) of resistance in ohms.
- B — Second significant figure.
- C — Decimal multiplier (number of zeros to be added).
- D — Tolerance of resistor in percent. No color is 20%.

EXAMPLE:

A resistor has the following color bands: A, yellow; B, violet; C, yellow; and D, silver. The significant figures are 4 and 7 (47) and the multiplier is 10,000. The value of resistance is 470,000 ohms and the tolerance is ±10%.

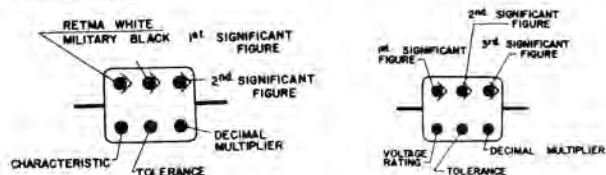

HOW TO DETERMINE THE VALUE OF A MICA CAPACITOR

EXAMPLES:

A capacitor with a 6 dot code (new RETMA standard REC-115A and military MIL-C-5A) has the following markings: Top row, left to right, white, green, brown; bottom row, right to left, brown, red, red. The first color white indicates mica. The significant figures are 5 and 1 (51), and the decimal multiplier is 10. So the capacitance is 510 μf. Tolerance is ±2%. For most general applications the characteristic can be ignored.

A capacitor with a 6 dot code has the following markings: Top row, left to right, brown, orange, red; bottom row, right to left, brown, red, green. Since the first dot is neither black or white, this is the obsolete RETMA code. The significant figures are 1, 3, and 2 (132), and the decimal multiplier is 10. So the capacitance is 1320 μf. Tolerance is ±2%. Voltage rating is 500 V DC.

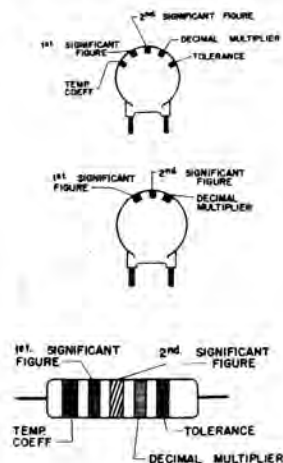

CERAMIC CAPACITOR COLOR CODE					
Color	Significant Figures	Decimal Figures	Tolerance		Temp. Coef. (Parts per million per °C.)
			10 μf or less (μf)	Over 10 μf (%)	
Black	0	1	±2.0	±20	0
Brown	1	10	±0.1	±1	-33
Red	2	100	—	±2	-75
Orange	3	1,000	—	±2.5	-150
Yellow	4	10,000	—	—	-220
Green	5	—	±0.5	±5	-330
Blue	6	—	—	—	-470
Violet	7	—	—	—	-750
Gray	8	0.01	±0.25	—	+150 to -1500
White	9	0.1	±1.0	±10	+100 to -750
Gold	—	—	—	—	—

HOW TO DETERMINE THE VALUE OF A CERAMIC CAPACITOR

EXAMPLES:

A ceramic tubular capacitor has the following color bands: Black, red, red, red, green. The significant figures are 2 and 2 (22), and the decimal multiplier is 100. The capacitance is, therefore, 2200 μf. Tolerance is ±5%. Temperature coefficient is 0. Voltage rating is always 500 V.

A ceramic disc capacitor has the following 5-dot code: Red, brown, green, red, green. The significant figures are 1 and 5 (15), and the decimal multiplier is 100. The capacitance is, therefore, 1500 μf. The tolerance is ±5%. The temperature coefficients — 75. Voltage rating is always 500 V.

A ceramic disc capacitor has the following 3-dot code: Green, brown, brown. The significant figures are 5 and 1 (51), and the decimal multiplier is 10. Therefore, the capacity is 510 μf. Voltage rating is always 500 V and the tolerance is always — 0.

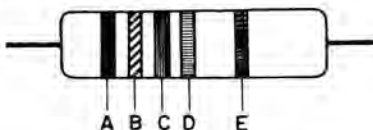

HOW TO DETERMINE THE VALUE OF A PAPER TUBULAR CAPACITOR

- A — First significant figure (digit) of capacitance in μf.
- B — Second significant figure.
- C — Decimal multiplier (number of zeroes to be added).
- D — Tolerance of capacitor in percent.
- E — Voltage rating.

EXAMPLE:

A paper tubular capacitor has the following color bands: A, brown; B, green; C, orange; D, black; and E, yellow. The significant figures are 1 and 5 (15) and the decimal multiplier is 1,000. The value of capacitance is 15,000 μf. The tolerance is ±20%. The voltage rating is 400 V DC.

TUBULAR PAPER CAPACITOR COLOR CODE				
Color	Significant Figures	Decimal Multiplier	Tolerance %	Voltage Rating (v d-c)
Black	0	1	±20	—
Brown	1	10	—	100
Red	2	100	—	200
Orange	3	1,000	±30	300
Yellow	4	10,000	—	400
Green	5	—	—	500
Blue	6	—	—	600
Violet	7	—	—	700
Gray	8	—	—	800
White	9	—	—	900
Gold	—	—	—	1,000
Silver	—	—	±10	—

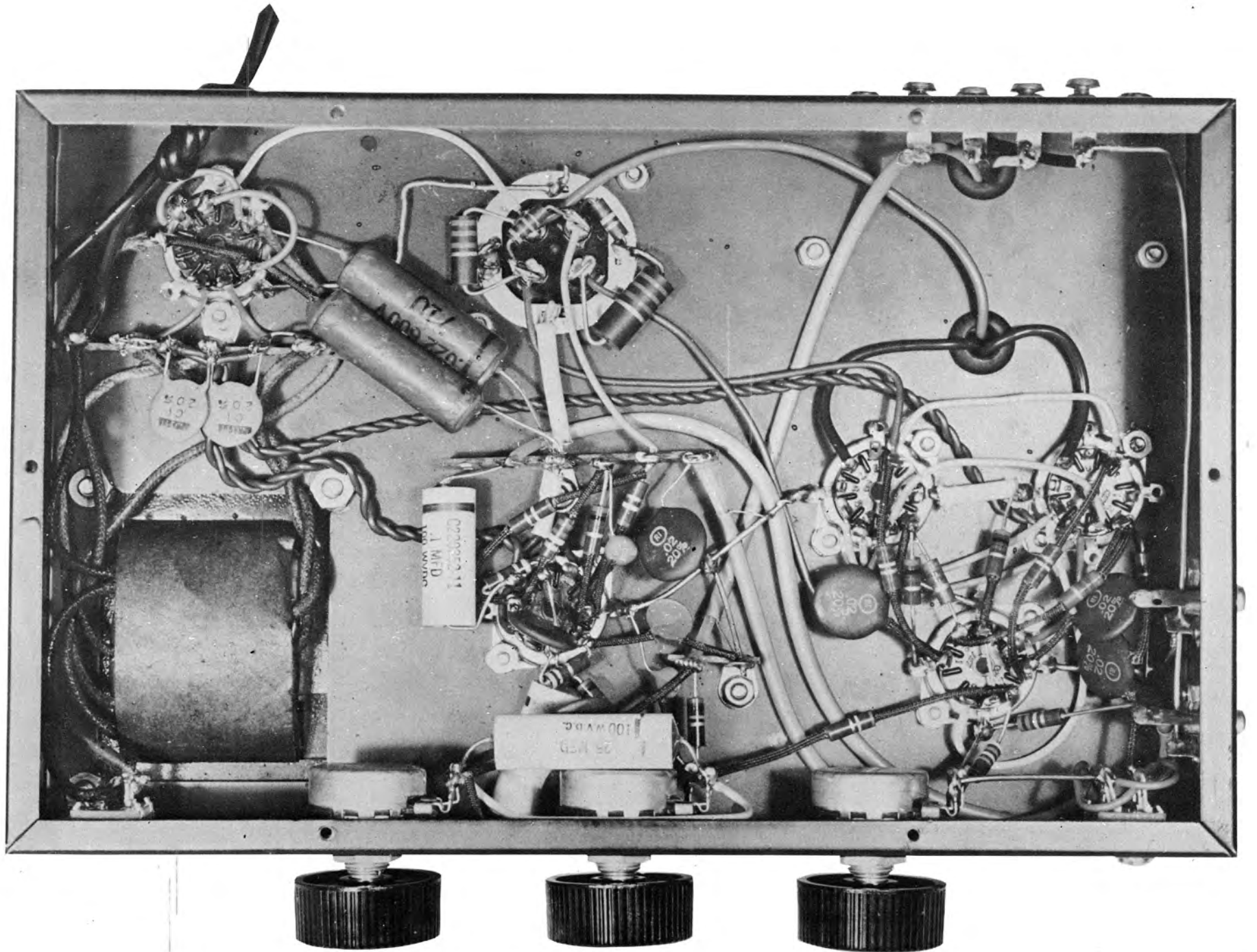

ALLIED RADIO CORPORATION
100 N. WESTERN AVENUE
CHICAGO, ILLINOIS 60680

Manufactured in Japan to
Allied's Specifications

Kit Stock No. 22-3784

Production No. 910-010N

Manual Stock No. 22-4099